

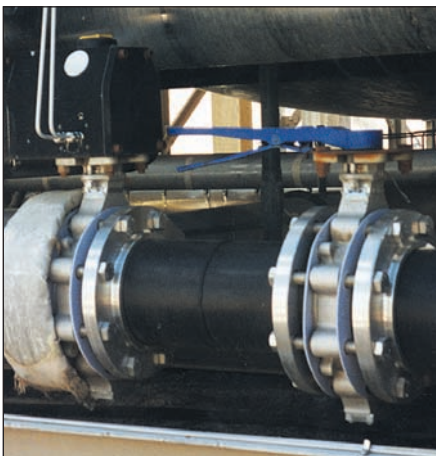

KEYSTONE

Features and Benefits

- Integrally cast mounting pad provides direct mounting of many actuators.
- Rocker-shaped gland bridge compensates for uneven adjustment of gland nuts.
- Extended neck allows for two inches of pipeline insulation.
- Flattened body bore at stem journal ports positions stem bearings near disc, providing maximum stem support.
- Disc taper pins are tangentially positioned half in disc and half in stem, placing them in compression rather than shear, which eliminates potential for failure.
- Integrally cast disc position stop perfectly locates the disc in seat, achieving maximum seat and seal life.
- Uninterrupted flange face retaining ring allows use of standard spiral wound gaskets and provides uni-directional dead-end service as standard. Bi-directional dead-end service is available.
- K-LOK polymer, elastomer, and fire-safe seats provide bi-directional, drop-tight closure in vacuum and throughout all pressure ranges, as well as at full rated differential pressure. A variety of materials allows optimum seat life in all applications.



Keystone K-LOK® High Performance Butterfly Valve Sizes 2" thru 36" ANSI Class 150 and 300



General Applications

- Airport Refueling
- Hydrocarbon Processing
- HVAC
- Chemical Processing
- Purified Gas
- Steam and Vacuum Services

Technical Data

Size Range:	2" thru 36"
Pressure Rating:	ANSI Class 150 and 300
Temperature Rating:	-20°F to 1000°F
Fire Safe Option	

K-LOK® is a registered trademark of Tyco International.

Keystone K-LOK Figure 360/362 and 370/372

Materials

Part	Material	Material standard
1. Stem and taper pins	17-4 PH 316B SS NITRONIC 50® K-Monel® 500 Inconel® 718	ASTM A564 Condition H1075 or H1100 ASTM A276-316 Condition B ASTM A276-XM19 QQ-N-286 UNS N005500 Class A age-hardened
2. Body	Carbon steel Stainless steel Nickel aluminum bronze	ASTM A216-WCB ASTM A351-CF8M MIL B24480 CDA C95800/ASTM B148
3. Gland bridge	17-4PH stainless steel	
4. Packing gland follower	316 stainless steel	
5. Stem packing	PTFE Graphite Style 9000 EVSP simplified 1	
6. Stem bearing	316 stainless steel/nitride	
7. Body gasket	Graphite	
8. Disc	316 stainless steel 316 stainless steel/ENP Monel®	ASTM A351-CF8M ASTM A351-CF8M/electroless nickel plated QQ-N-288 Composition A
9. Seat	Polymer Elastomer Metal Fire-safe	PTFE, RTFE, UHMWPE NBR, EPDM, Fluoroelastomer (FKM) 316 stainless steel, Monel® RTFE/316 stainless steel
10. Seat backing ring	Stainless steel	
11. Seat retainer ring	Carbon steel 316 Stainless steel Nickel aluminum bronze	
12. Flange locator plate	Stainless steel Carbon steel/zinc plated	
13. Disc locating shoulder	316 stainless steel	
14. Bottom cover gasket	Non-asbestos fiber Graphite	
15. Bottom cover plate	316 stainless steel	ASTM A743 - CF8M
16. Thrust washer	Stainless steel nitride	

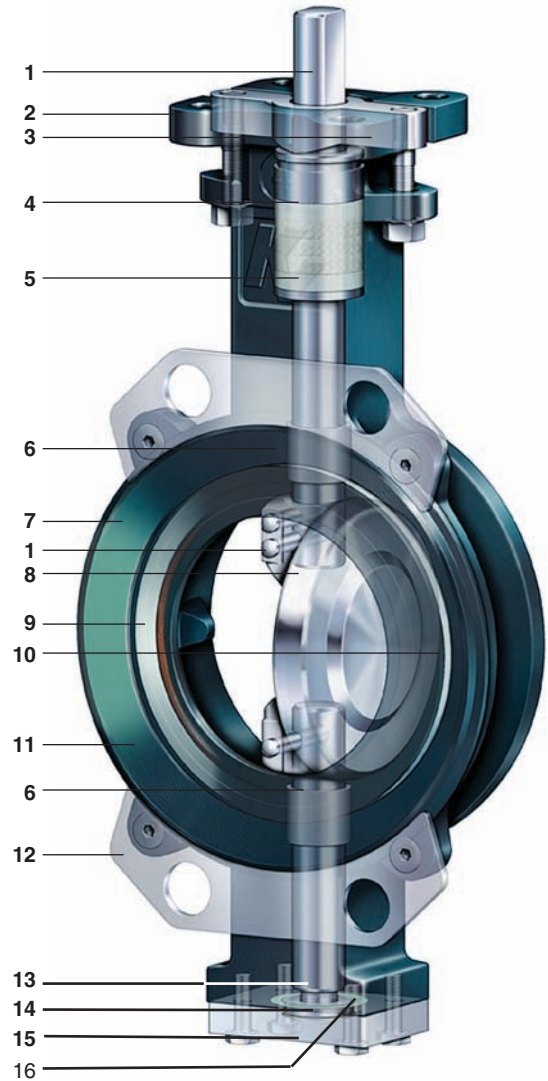

Recommended Standards and Specifications

ANSI	– B16.34	Steel valves
	– B31.1	Power piping
	– B31.3	Chemical plant and petroleum refinery piping
	– B16.5	Steel pipe flanges and flange fittings
MSS	– SP-6	Standard finishes for pipe flanges
	– SP-25	Standard marking systems for valves
	– SP-55	Quality standard for steel casting
	– SP-61	Pressure testing of steel valves
	– SP-67	Butterfly valves
	– SP-68	High pressure offset disc butterfly valves
API	– 609	Butterfly valves
	– 607	Fire test for soft seated quarter-turn valves
	– 598	Valve inspection and test
BS	– 5146	Inspection and test of steel valves for the petroleum, petrochemical and allied industries
	– 4504	Flanges and bolting for pipes, valves and fittings
DIN	– 3230	Technical conditions of delivery for valves
ISO	– 5752	Metal valves for use in flanged pipe systems
	– 2084	Pipeline flanges for general use
JIS	– 2215	Basic dimensions for steel pipe flanges

Notes

1. A product of Coltec Industries.
2. NITRONIC 50® is a registered trademark of Armco, Inc.
3. Monel®, K-Monel®, and Inconel® are registered trademarks of the INCO Family of Products.

Principles of Operation

Double Offset Disc/stem

K-LOK's unique two-piece stem and double-offset disc/stem design allows for high cycling and creates a lower disc profile with increased capacity and a range of 33:1.

In addition to increasing the flow area across the disc, this design minimizes wear points between seat and disc.

The first offset is achieved by locating the stems downstream of the center-line of the seat. This allows for a totally unobstructed 360° sealing surface.

The second offset locates the stems off-center of the vertical axis of the seat.

The combination of these two offsets creates a camming effect as the disc swings into and out of the seat. The disc lifts quickly out of the seat in the first few degrees of travel and does not contact the seat again until it is nearly closed. There are no wear points between the seat and disc, while operating torques are reduced and seat life is extended.

Two-piece Stem vs. One-piece Stem

K-LOK's disc geometry maximizes flow capacity by increasing the available flow area through the valve. This increase in disc efficiency results in a higher valve C_v .

First Offset

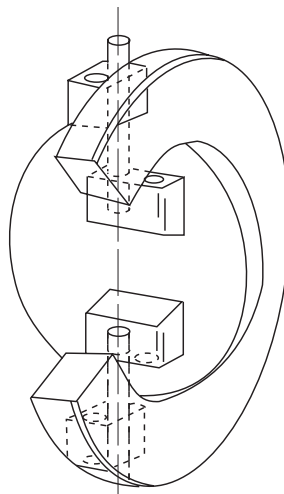

Second Offset

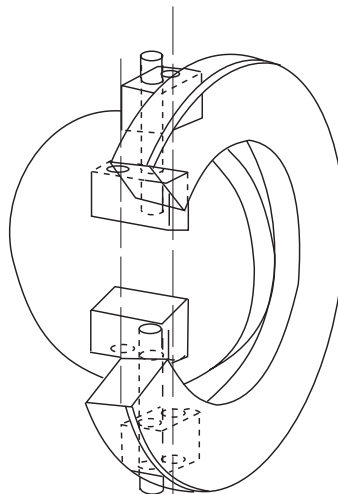

Double Offset

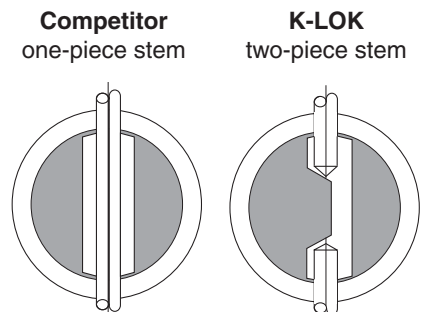
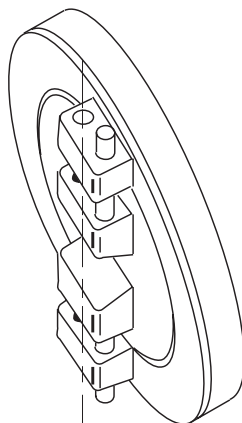

Aspect Ratio = Open Area ÷ Disc Area

Fire-Safe Valve API 607 4th Edition Approved by Third Party Witness

The K-LOK fire-safe design uses a stainless steel or Monel® alloy seat of convoluted shape that mates with an RTFE member. In the full-closed position, the K-LOK provides continuous two-plane contact between the disc and both metal and RTFE seats. The fire-safe seat utilizes wire windings to provide the circumferential stiffness necessary to maintain interference between disc and seat.

Fire-Safe Seat



Fire-Safe Packing



K-Lok fire-safe packing is composed of three rings of preformed graphite between one ring of woven graphite rope at the top and bottom.

This arrangement creates a superior, high temperature seal against the outer wall of the packing box and around the rotating stem.

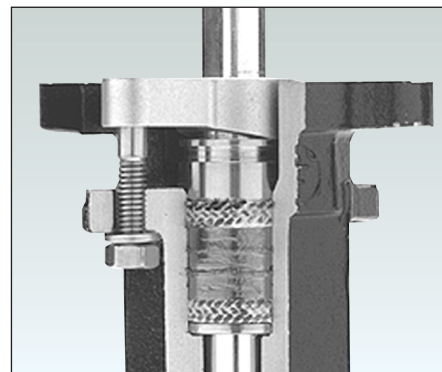
Fire-Safe Packing

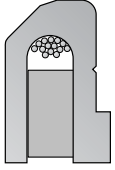
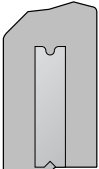

Seat Materials

Seat	Material	Typical Applications	
PTFE	Polytetrafluoroethylene	Pharmaceuticals, water, jet fuel, river water, air	
RTFE	Reinforced Polytetrafluoroethylene	Saturated steam, chlorine, ammonia, natural gas vacuum, oxygen, nitrogen	
UHMWPE	Ultra high molecular weight polyethylene	Abrasives, suspended solids, scaling mediums	
Wire Wrap Backing Ring	302 stainless steel braided wire Polyester or phenolic stainless steel	General purpose services Steam, ammonia	
EPDM NBR Fluoroelastomer (FKM)		Cooling water, chilled water, HVAC, river water intakes, abrasives, vacuum	
Backing ring	Carbon steel		
Metal	316 Stainless steel (flash chrome coated)	High temperature, low temperature, abrasives, fly ash, slurries	
Wire Wrap	316 stainless steel		
Fire-safe	Reinforced polytetrafluoroethylene combined with 316 Stainless Steel (flash chrome coated)	Fire-safe installations, abrasives, slurries, steam	
Wire Wrap	316 stainless steel		

Seat Design

The K-LOK seat is a true interference seat design and does not rely on line pressure to assist in sealing. All seats seal drop-tight bi-directionally at low pressure as well as high pressure.

Polymer (PTFE, RTFE and UHMWPE) seats incorporate a stainless steel braided wire winding, enclosed in a U-shape envelope to provide seating energy and memory. This wire winding allows axial flexibility in both directions of flow. The winding also allows radial flexibility when the disc is not fully closed, reducing seat/disc interference, seat wear and stem torque. When the disc closes, it provides circumferential stiffness and assures the required disc/seat seals tight.

Elastomer seats are molded around a stack of V-shaped steel rings that provide the same stability, support and flexure as the wire windings in polymer seats.

Metal seats employ a stainless steel or Monel® ring of convoluted shape, reinforced by stainless steel wire windings. The thin, convoluted shape allows for expansion and contraction from thermal cycling. Long life is assured by flash coating the seat with chrome.



ANSI/FCI 70-2 Control Valve Seat Leakage, Tolerances, and Test Specifications

ANSI B16.104-1976	Maximum Leakage			Test Medium	Pressure and Temperature
Class VI	Nominal Port Diameter (in.)	Bubbles per Minute ³	ml. per Minute	Air or Nitrogen	Service ΔP or 50 psig [3.4 bar differential], whichever is lower, at 50° to 125°F [10° to 52°C]
	2	3	0.45		
	2½	4	0.60		
	3	6	0.90		
	4	11	1.70		
	6	27	4.00		
	8	45	6.75		
Class V	5 x 10-4 ml/min/psig/in. port dia. [5 x 10-12 m³/sec/bar differential/mm port dia.]			Water	Service ΔP at 50° to 125°F [10° to 52°C]
Class IV	0.01% valve capacity at full travel			Air or Water	Service ΔP or 50 psig [3.4 bar differential], whichever is lower, at 50° to 125°F [10° to 52°C]

Notes

1. K-LOK polymer, elastomer and fire-safe seats provide ANSI Class VI shutoff.
2. K-LOK metal seats provide ANSI Class IV shutoff.
3. Using the ANSI/FCI specified calibrated measuring device.

Reference ANSI/FCI 70-2 for further information.

C_v Values vs. Travel Position

Size (in.)	Angle of Opening								CL 150	CL 300
	10°	20°	30°	40°	50°	60°	70°	80°	90°	90°
2	6	10	19	34	51	78	105	134	163	160
2½	6	10	19	34	53	80	111	148	175	170
3	8	12	24	43	67	100	139	186	220	215
4	16	23	44	80	130	194	269	360	425	413
5	30	44	83	149	242	366	504	673	795	785
6	50	70	130	230	370	550	760	1,010	1,195	1,140
8	83	117	251	437	695	1,052	1,496	2,001	2,440	2,300
10	144	202	454	754	1,185	1,821	2,611	3,541	4,540	4,333
12	208	304	678	1,051	1,625	2,766	3,838	5,325	6,915	6,600
14	257	360	747	1,186	1,909	3,121	4,416	6,225	8,300	7,920
16	308	432	803	1,422	2,289	3,614	5,251	7,530	10,040	9,580
18	373	548	1,121	1,869	2,990	4,735	6,728	9,845	12,460	11,890
20	463	680	1,390	2,315	4,010	6,175	8,795	12,655	15,430	14,720
24	650	991	2,076	3,803	6,060	9,091	13,301	18,466	21,660	20,665
30	1,015	1,550	3,240	4,670	9,460	14,200	21,400	29,800	36,000	35,500
36	1,460	2,300	4,640	5,950	13,700	21,000	30,400	44,000	56,000	55,500

Vacuum Rating

The combination of interference fit seats and bi-directional packing makes the K-LOK especially well suited for vacuum service.

Standard K-LOK high performance valves are rated to an absolute pressure of 4 x 10⁻⁵ inch Hg. Higher vacuum applications are available.

Actuator Selection

Actuator Type	Figure	Remark
Handle	F401	Lever lock
Gear	F420 and F500 Series	
Pneumatic	F79U	With extended travel adapter
Gear & Pneumatic	F453 + F79U	Declutchable gear unit provides manual override for the Keystone pneumatic actuator
Electric	F777	

Common Available Trims

Figure Number	Valve Type
F360	ANSI Class 150, Wafer
F362	ANSI Class 150, Full-lug
F370	ANSI Class 300, Wafer
F372	ANSI Class 300, Full-lug

To order a K-LOK, specify the valve size, the valve figure number (listed above) and the specific application trim code. The most common codes, together with the materials of construction, are listed below. (Example: 10 inch F360-104)

General Purpose Trims (up to 250°F)

Trim Code	Body	Disc	Shaft	Seat/Backing Ring	Bushing	Packing
106	Steel	316 SS/ENP	17-4PH SS	UHMWPE/polyester	RTFE/fiberglass epoxy	PTFE
107	316 SS	316 SS/ENP	17-4PH SS	UHMWPE/polyester	RTFE/fiberglass epoxy	PTFE

General Purpose Trims (up to 500°F)

Trim Code	Body	Disc	Shaft	Seat/Backing Ring	Bushing	Packing
123	Steel	316 SS/ENP	17-4PH SS	RTFE/SS	316 SS DU	PTFE
124	316 SS	316 SS/ENP	17-4PH SS	RTFE/SS	316 SS DU	PTFE
158	Steel	316 SS	17-4PH SS	RTFE/SS	316 SS DU	PTFE
159	316 SS	316 SS	17-4PH SS	RTFE/SS	316 SS DU	PTFE

Metal Seated – High Temperature Trims

Trim Code	Body	Disc	Shaft	Seat/Backing Ring	Bushing	Packing
113	Steel	316 SS/ENP	17-4PH SS	316 SS chrome plated	316 SS nitrided	Graphite
114	316 SS	316 SS/ENP	17-4PH SS	316 SS chrome plated	316 SS nitrided	Graphite

Corrosion Resistant Trims

Trim Code	Body	Disc	Shaft	Seat/Backing Ring	Bushing	Packing
133 (2½" - 8")	316 SS	316 SS	316 SS Cond. B	RTFE/Polyester	RTFE/fiberglass epoxy	PTFE
134 (10" - 24")	316 SS	316 SS	NITRONIC 50®	RTFE/Polyester	RTFE/fiberglass epoxy	PTFE
135 (2½" - 8")	316 SS	316 SS/ENP	316 SS Cond. B	316 SS chrome plated	RTFE/fiberglass epoxy	PTFE
136 (10" - 24")	316 SS	316 SS/ENP	NITRONIC 50®	316 SS chrome plated	RTFE/fiberglass epoxy	PTFE

Fire-Safe Trims

Trim Code	Body	Disc	Shaft	Seat/Backing Ring	Bushing	Packing
115	Steel	316 SS/ENP	17-4PH SS	316 SS chrome plated and RTFE	316 SS nitrided RTFE/fiberglass epoxy	Graphite
116	316 SS	316 SS/ENP	17-4PH SS	316 SS chrome plated and RTFE	316 SS nitrided RTFE/fiberglass epoxy	Graphite

Note

Other trims are available; please contact a Tyco Valves & Controls distributor.

Seating and Un-seating Torque

Seating and un-seating torques are a function of the size of the valve and the shutoff pressure of the system.

Specific torque ratings can be found in the Seating/Un-seating chart at the intersection of the 'size' row and the 'shutoff pressure' column.

Torques listed are for PTFE and RTFE seated valves. For different seat materials specific multipliers are to be used as stated.

All torques listed are for normal service conditions (i.e. operating frequency is a minimum of once per month; disc corrosion is expected to be mild or minor, the media is a clean gas, liquid or steam, and is non-abrasive) and chemical affects upon the seat are minor.

PTFE and RTFE Bi-Directional Seating and Un-Seating Torque Values

Valve Size (inch)	Shaft Mounting Code (ANSI)		Seating and Un-seating Torque (lbs. in.) System Shutoff Pressure (psig)					
	150	300	150	200	285	400	500	740
2	BAB	BAB	220	280	380	460	520	580
2½	BAB	BAB	220	280	380	460	520	580
3	BAC	BAC	250	320	430	520	590	650
4	BAD	BAD	475	600	820	995	1,120	1,235
5	BAD	BAD	925	1,125	1,350	1,570	1,750	1,900
6	CAD/CAE*	CAE	1,370	1,600	1,850	2,150	2,390	2,900
8	CAF	CAF	2,060	2,330	3,200	4,020	4,870	6,720
10	CAF/CAG*	CAG	3,340	3,650	4,700	6,250	7,450	9,850
12	DAG	DAG	4,590	5,250	6,400	8,160	9,690	12,940
14	DAH	DAJ	6,750	7,560	9,150	11,450	13,300	17,200
16	DAH	DAK	9,350	10,450	12,600	15,000	17,500	22,200
18	DAJ	DBA	11,900	13,300	15,800	19,500	21,900	28,500
20	DAK	LAX	15,600	17,500	21,000	25,200	28,700	36,140
24	DAK	MAY	21,700	25,340	30,600	36,900	42,100	54,000
30	MAZ	NAW	29,200	35,000	43,500	54,500	62,500	80,000
36	MBE	EBD	52,500	58,500	70,000	85,000	97,500	125,000

*CAE and CAG mounting codes apply for shaft mounting of UHMWPE, metal and fire-safe seats.

Notes

- Torques are applicable only to PTFE and RTFE seats. For fire-safe and metal seats, select only the torque applicable for the valve at 285 psig and multiply by 2.0.
- For other seat materials, select the torque applicable for the maximum differential pressure and multiply by the following factor:

EPDM/NBR/Fluoroelastomer (FKM)	x 1.4
UHMWPE (Clean Service)	x 1.3
UHMWPE (Slurry Service)	x 1.7

Extension Brackets For Various Temperatures

Pipeline Fluid Temperature	Required Extension Lengths (inches)				
	Handle	Gear	200°F Std. F79U	450°F High Temp. F79U	Standard F777
-100°F - 375°F	–	–	–	–	–
376°F - 460°F	4	–	–	–	4
461°F - 560°F	6	4	4	–	4
561°F - 650°F	6	4	4	–	4
651°F - 725°F	6	6	6	4	6
726°F - 825°F	8	8	8	6	8
826°F - 925°F	10	8	8	6	8
926°F - 1,000°F	10	10	10	8	10

Notes

1. Surrounding air temperature is assumed to be 70°F. For every degree over 100°F of the surrounding air, deduct 2 degrees from the temperature ranges shown above.
(Example: 125°F external reduces maximum temperature values to 325, 410, 510, 600, etc.)
2. Valves may be insulated or uninsulated.
3. Brackets may be open rectangular tubes or the standard closed Keystone tubular stem extensions.
4. All actuators have a maximum service temperature (outside atmosphere). These temperature limitations apply regardless of K-LOK extension lengths.

Handle Capacity - inches, ANSI

Handle Size	Valve Size	RTFE/PTFE		UHMWPE		EPDM/NBR		Metal Fire-safe 150/300
		150	300	150	300	150	300	
10½	2	Yes	Yes	Yes	Yes	Yes	Yes	Yes
10½	2¼	Yes	Yes	Yes	Yes	Yes	Yes	Yes
10½	3	Yes	Yes	Yes	Yes	Yes	Yes	Yes
10½	4	Yes	Yes	Yes	No	Yes	Yes	Yes
10½	5	Yes	No	No	No	No	No	No
14	6	No	No	No	No	No	No	No

Notes

1. The maximum safe pull made by an operator is about 120 pounds. The effective length of the handle moment arm is 9¼ inches for the 10½ inch handle and 12¾ inches for the 14 inch handle. This is based on the average operator's hand width.
2. Chart is based on full pressure differential. K-LOKs up to 6 inch can be fitted with a handle when pressure is reduced. Please contact Tyco Valves & Controls for assistance.

K-LOK Services

Many services have specific requirements. Tyco Valves & Controls can meet most of these needs. The K-LOK product line can be ordered for the following special services:

- Food processing
- Sour gas
- Military
- Vacuum
- Oxygen
- Pharmaceutical
- Steam
- Steam jacketed
- Ammonia
- Chlorine
- Reverse osmosis
- Category 'M' fluids
- Slurry
- Flow control
- Modulating control
- On/off control
- Dead-end service

Recommended Flange Bolt Lengths

Lugged Body 150 Class - Fig. 362

Valve Size (in.)	Qty.	Hex Head Bolt Size	Machine Bolt Length (in.)	Qty.	All Thread Size	Thread Length (in.)
2	4	5/8 - 11UNC	x 1 3/4	4	5/8 - 11UNC	x 2 1/2
	4	5/8 - 11UNC	x 2	4	5/8 - 11UNC	x 2 3/4
2 1/2	8	5/8 - 11UNC	x 1 3/4	8	5/8 - 11UNC	x 2 1/2
3	4	5/8 - 11UNC	x 2	4	5/8 - 11UNC	x 2 3/4
	4	5/8 - 11UNC	x 1 1/2	4	5/8 - 11UNC	x 2 1/2
4	8	5/8 - 11UNC	x 2	8	5/8 - 11UNC	x 2 3/4
	8	5/8 - 11UNC	x 1 3/4	8	5/8 - 11UNC	x 2 1/2
5	16	3/4 - 10UNC	x 2	16	3/4 - 10UNC	x 3
	6	8	3/4 - 10UNC	x 2 1/4	8	3/4 - 10UNC
8		8	3/4 - 10UNC	x 2	8	3/4 - 10UNC
	8	8	3/4 - 10UNC	x 2 1/2	8	3/4 - 10UNC
8		8	3/4 - 10UNC	x 2	8	3/4 - 10UNC
	10	12	7/8 - 9UNC	x 2 3/4	12	7/8 - 9UNC
12		12	7/8 - 9UNC	x 2 1/4	12	7/8 - 9UNC
	12	12	7/8 - 9UNC	x 3	12	7/8 - 9UNC
12		12	7/8 - 9UNC	x 2 1/2	12	7/8 - 9UNC
	14	12	1 - 8UNC	x 3 1/2	12	1 - 8UNC
12		1	- 8UNC	x 2 3/4	12	1 - 8UNC
	16	16	1 - 8UNC	x 4	16	1 - 8UNC
16		1	- 8UNC	x 2 3/4	16	1 - 8UNC
	18	16	1 1/8 - 8UNC	x 4	16	1 1/8 - 8UNC
16		1 1/8 - 8UNC	x 3 1/2	16	1 1/8 - 8UNC	x 5
	20	16	1 1/8 - 8UNC	x 4 1/4	16	1 1/8 - 8UNC
16		1 1/8 - 8UNC	x 4	16	1 1/8 - 8UNC	x 5 1/2
	4	1 1/8 - 8UNC	x 3 1/2	4	1 1/8 - 8UNC	x 5
4		1 1/8 - 8UNC	x 3	4	1 1/8 - 8UNC	x 4 1/2
	24	20	1 1/4 - 8UNC	x 5	20	1 1/4 - 8UNC
20		1 1/4 - 8UNC	x 4 1/2	20	1 1/4 - 8UNC	x 6 1/4
	30	24	1 1/4 - 8UNC	x 5 3/4	24	1 1/4 - 8UNC
24		1 1/4 - 8UNC	x 5 1/2	24	1 1/4 - 8UNC	x 7 1/4
	4	1 1/4 - 8UNC	x 3 1/2	4	1 1/4 - 8UNC	x 5 1/4
4		1 1/4 - 8UNC	x 3 1/2	4	1 1/4 - 8UNC	x 5
	36	28	1 1/2 - 8UNC	x 7	28	1 1/2 - 8UNC
28		1 1/2 - 8UNC	x 6	28	1 1/2 - 8UNC	x 8
	4	1 1/2 - 8UNC	x 5	4	1 1/2 - 8UNC	x 6 3/4
4		1 1/2 - 8UNC	x 4	4	1 1/2 - 8UNC	x 6

Wafer Body

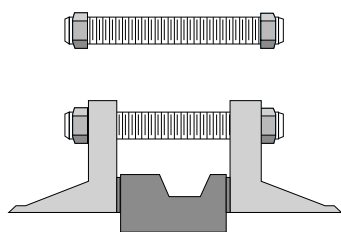

Lugged Body 300 Class - Fig. 372

Valve Size (in.)	Qty.	Hex Head Bolt Size	Machine Bolt Length (in.)	Qty.	All Thread Size	Thread Length (in.)
2	16	5/8 - 11UNC	x 2	16	5/8 - 11UNC	x 2 3/4
	2 1/2	8	3/4 - 10UNC	x 1 3/4	8	3/4 - 10UNC
8		8	3/4 - 10UNC	x 2 1/4	8	3/4 - 10UNC
	3	8	3/4 - 10UNC	x 2 1/4	8	3/4 - 10UNC
8		8	3/4 - 10UNC	x 1 3/4	8	3/4 - 10UNC
	4	8	3/4 - 10UNC	x 2 1/2	8	3/4 - 10UNC
8		8	3/4 - 10UNC	x 2	8	3/4 - 10UNC
	5	8	3/4 - 10UNC	x 2 1/2	16	3/4 - 10UNC
8		8	3/4 - 10UNC	x 2 1/4	24	3/4 - 10UNC
	12	3/4 - 10UNC	x 2 1/4			
8	12	7/8 - 9UNC	x 3 1/4	12	7/8 - 9UNC	x 4 1/2
	12	7/8 - 9UNC	x 2 1/2	12	7/8 - 9UNC	x 3 1/2
10	16	1 - 8UNC	x 3 3/4	16	1 - 8UNC	x 5
	16	1 - 8UNC	x 3	16	1 - 8UNC	x 4 1/4
12	16	1 1/8 - 8UNC	x 4	16	1 1/8 - 8UNC	x 5 1/2
	16	1 1/8 - 8UNC	x 3 1/2	16	1 1/8 - 8UNC	x 4 3/4
14	16	1 1/8 - 8UNC	x 4 1/2	16	1 1/8 - 8UNC	x 6
	16	1 1/8 - 8UNC	x 4	16	1 1/8 - 8UNC	x 5 1/2
4	1 1/8 - 8UNC	x 3 1/4	4	1 1/8 - 8UNC	x 4 3/4	
	4	1 1/8 - 8UNC	x 3	4	1 1/8 - 8UNC	x 4 1/2
16	16	1 1/4 - 8UNC	x 5	32	1 1/4 - 8UNC	x 6 1/2
	16	1 1/4 - 8UNC	x 4 1/2	32	1 1/4 - 8UNC	x 6 1/4
4	1 1/4 - 8UNC	x 3 1/4	4	1 1/4 - 8UNC	x 4 3/4	
	4	1 1/4 - 8UNC	x 3	4	1 1/4 - 8UNC	x 4 1/2
18	40	1 1/4 - 8UNC	x 5 1/4	40	1 1/4 - 8UNC	x 6 3/4
	4	1 1/4 - 8UNC	x 3 1/2	8	1 1/4 - 8UNC	x 5
4	1 1/4 - 8UNC	x 3	8	1 1/4 - 8UNC	x 4 3/4	
	20	40	1 1/4 - 8UNC	x 5 1/2	20	1 1/4 - 8UNC
4	1 1/4 - 8UNC	x 4	20	1 1/4 - 8UNC	x 7	
	4	1 1/4 - 8UNC	x 3 3/4	8	1 1/4 - 8UNC	x 5 1/2
24	20	1 1/2 - 8UNC	x 6 1/2	20	1 1/2 - 8UNC	x 8 1/2
	20	1 1/2 - 8UNC	x 6	20	1 1/2 - 8UNC	x 8
4	1 1/2 - 8UNC	x 4 3/4	4	1 1/2 - 8UNC	x 6 3/4	
	4	1 1/2 - 8UNC	x 4 1/4	4	1 1/2 - 8UNC	x 6 1/4
30	48	1 3/4 - 8UNC	x 8 1/4	24	1 3/4 - 8UNC	x 10 1/2
	8	1 3/4 - 8UNC	x 5 1/2	24	1 3/4 - 8UNC	x 10 1/4
36	56	2 - 8UNC	x 9 1/4	56	2 - 8UNC	x 12
	8	2 - 8UNC	x 6 1/4	8	2 - 8UNC	x 9

Lugged Body

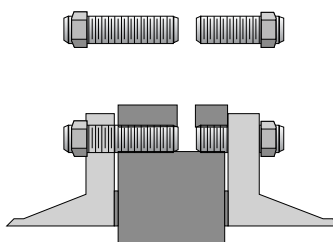

Wafer Body 150 Class - Fig. 360

Valve Size (in.)	Qty.	Hex Head Bolt Size	Machine Bolt Length (in.)	Qty.	All Thread Size	Thread Length (in.)
2	4	5/8 - 11UNC	x 5	4	5/8 - 11UNC	x 5 1/2
	2 1/2	4	5/8 - 11UNC	x 4 1/2	4	5/8 - 11UNC
3	4	5/8 - 11UNC	x 4 1/2	4	5/8 - 11UNC	x 5 1/4
	4	8	5/8 - 11UNC	x 4 3/4	8	5/8 - 11UNC
5	8	3/4 - 10UNC	x 5	8	3/4 - 10UNC	x 6
	6	8	3/4 - 10UNC	x 5 1/4	8	3/4 - 10UNC
8		8	3/4 - 10UNC	x 5 3/4	8	3/4 - 10UNC
	10	12	7/8 - 9UNC	x 6 1/4	12	7/8 - 9UNC
12		12	7/8 - 9UNC	x 7	12	7/8 - 9UNC
	14	12	1 - 8UNC	x 7 1/2	12	1 - 8UNC
16		16	1 - 8UNC	x 8	16	1 - 8UNC
	18	16	1 1/8 - 8UNC	x 9 1/4	16	1 1/8 - 8UNC
20		16	1 1/8 - 8UNC	x 10	16	1 1/8 - 8UNC
	4	1 1/8 - 8UNC	x 3 1/2	4	1 1/8 - 8UNC	x 5
4		1 1/8 - 8UNC	x 3	4	1 1/8 - 8UNC	x 4 1/2
	24	20	1 1/4 - 8UNC	x 11 1/2	20	1 1/4 - 8UNC
30		24	1 1/4 - 8UNC	x 13 1/4	24	1 1/4 - 8UNC
	4	1 1/4 - 8UNC	x 3 1/2	4	1 1/4 - 8UNC	x 5 1/4
4		1 1/4 - 8UNC	x 3 1/4	4	1 1/4 - 8UNC	x 4 3/4
	36	28	1 1/2 - 8UNC	x 15	28	1 1/2 - 8UNC
4		1 1/2 - 8UNC	x 5	4	1 1/2 - 8UNC	x 6 3/4
	4	1 1/2 - 8UNC	x 4	4	1 1/2 - 8UNC	x 6

Wafer Body 300 Class - Fig. 370

Valve Size (in.)	Qty.	Hex Head Bolt Size	Machine Bolt Length (in.)	Qty.	All Thread Size	Thread Length (in.)
2	8	5/8 - 11UNC	x 5 1/4	8	5/8 - 11UNC	x 6 1/4
	2 1/2	8	3/4 - 10UNC	x 4 3/4	8	3/4 - 10UNC
3	8	3/4 - 10UNC	x 5	8	3/4 - 10UNC	x 6
	4	8	3/4 - 10UNC	x 5 1/2	8	3/4 - 10UNC
5	8	3/4 - 10UNC	x 6	8	3/4 - 10UNC	x 7
	6	12	3/4 - 10UNC	x 6	12	3/4 - 10UNC
8	12	7/8 - 10UNC	x 7 1/4	12	7/8 - 9UNC	x 8 1/2
	10	16	1 - 8UNC	x 8 1/4	16	1 - 8UNC
12	16	1 1/8 - 8UNC	x 9	16	1 1/8 - 8UNC	x 10 1/2
	14	16	1 1/8 - 8UNC	x 10 1/4	16	1 1/8 - 8UNC
4	1 1/8 - 8UNC	x 3 1/4	4	1 1/8 - 8UNC	x 4 3/4	
	4	1 1/8 - 8UNC	x 3	4	1 1/8 - 8UNC	x 4 1/2
16	16	1 1/4 - 8UNC	x 11 1/2	16	1 1/4 - 8UNC	x 13
	4	1 1/4 - 8UNC	x 3 1/4	4	1 1/4 - 8UNC	x 4 3/4
4	1 1/4 - 8UNC	x 3	4	1 1/4 - 8UNC	x 4 1/2	
	18	20	1 1/4 - 8UNC	x 12	20	1 1/4 - 8UNC
4		1 1/4 - 8UNC	x 3 1/2	4	1 1/4 - 8UNC	x 5
20	20	1 1/4 - 8UNC	x 13	20	1 1/4 - 8UNC	x 14 1/2
	8	1 1/4 - 8UNC	x 4	8	1 1/4 - 8UNC	x 5 1/2
24	20	1 1/2 - 8UNC	x 14 1/2	20	1 1/2 - 8UNC	x 16 1/2
	4	1 1/2 - 8UNC	x 4 3/4	4	1 1/2 - 8UNC	x 6 1/2
4	1 1/2 - 8UNC	x 4 1/4	4	1 1/2 - 8UNC	x 6 1/4	
	30	24	1 1/2 - 8UNC	x 19	24	1 3/4 - 8UNC
8		1 3/4 - 8UNC	x 5 1/2	8	1 3/4 - 8UNC	x 7 3/4
36	28	2 - 8UNC	x 21 1/2	28	2 - 8UNC	x 24
	8	2 - 8UNC	x 6 1/4	8	2 - 8UNC	x 9

Wafer Style

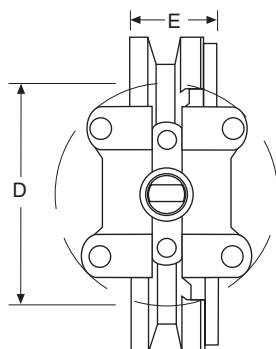
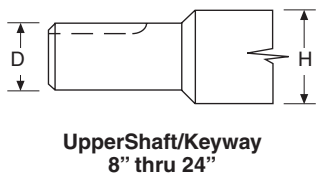

Top Plate View

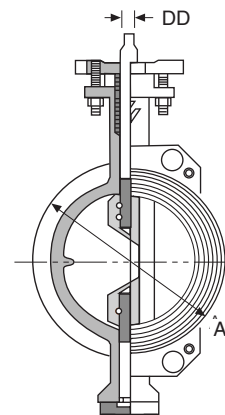
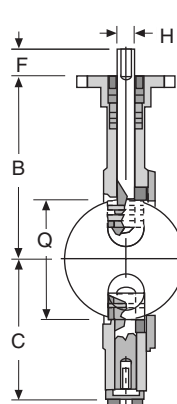

ANSI Class 150 Figure 360 Dimensions (inches)

Size	A	B	C	D	E	F	G	H	Q	Top Plate Drilling			Wt. Lbs.	Actuator Code	
										DD or Keyway	Bolt Circle	No. Holes Dia.			
2	4 1/8	6	4 1/16	4	2 3/8	1 1/4	9/16	9/16	1 7/8	3/8	3 1/4	4	7/16	8	BAB
2 1/2	4 1/8	6	4 1/16	4	1 7/8	1 1/4	9/16	9/16	2 3/8	3/8	3 1/4	4	7/16	9	BAB
3	5	6 5/8	4 5/8	4	1 7/8	1 1/4	5/8	5/8	2 15/16	7/16	3 1/4	4	7/16	12	BAC
4	6 3/16	7 1/2	5 1/2	4	2 1/8	1 1/4	3/4	3/4	3 7/8	1/2	3 1/4	4	7/16	20	BAD
5	7 1/4	7 9/16	5 9/16	4	2 1/4	1 1/4	3/4	3/4	4 13/16	1/2	3 1/4	4	7/16	25	BAD
6	8 19/32	8 3/4	6 11/16	6	2 1/4	1 1/4	3/4	7/8	5 13/16	1/2	5	4	9/16	32	CAD
6*	8 19/32	8 3/4	6 11/16	6	2 1/4	1 1/4	7/8	7/8	5 13/16	5/8	5	4	9/16	33	CAE
8	10 5/8	10 1/8	8 1/16	6	2 1/2	2	1 1/8	1 1/8	7 5/8	1/4 x 1/4 x 1 5/8	5	4	9/16	50	CAF
10	12 3/4	11 3/8	9 3/8	6	2 13/16	2	1 1/8	1 3/8	9 9/16	1/4 x 1/4 x 1 5/8	5	4	9/16	77	CAF
10*	12 3/4	11 3/8	9 3/8	6	2 13/16	3	1 3/8	1 3/8	9 9/16	5/16 x 5/16 x 2 5/8	5	4	9/16	78	CAG
12	14 3/4	13	10 9/16	8	3 3/16	3	1 3/8	1 1/2	11 3/8	5/16 x 5/16 x 2 5/8	6 1/2	4	1 3/16	124	DAG
14	16 1/4	13 3/4	11 9/16	8	3 5/8	3	1 5/8	1 5/8	12 1/2	3/8 x 3/8 x 2 5/8	6 1/2	4	1 3/16	141	DAH
16	18 1/2	14 1/2	12 9/16	8	4	3	1 5/8	1 3/4	14 5/16	3/8 x 3/8 x 2 5/8	6 1/2	4	1 3/16	230	DAH
18	21	16	13 7/16	8	4 1/2	4 1/4	1 7/8	1 7/8	16 1/8	1/2 x 3/8 x 3 7/8	6 1/2	4	1 3/16	305	DAJ
20	23	17 7/16	15 1/16	8	5	4 1/4	2 1/4	2 1/4	17 15/16	1/2 x 3/8 x 3 7/8	6 1/2	4	1 3/16	350	DAK
24	27 1/2	19 11/16	17 7/16	8	6 1/16	4 1/4	2 1/4	2 1/2	21 9/16	1/2 x 3/8 x 3 7/8	6 1/2	4	1 3/16	620	DAK
30	33 3/4	24 1/2	20 3/4	9 1/2	7 3/8	7	3	3	27 1/2	3/4 x 3/4 x 5 7/8	9 3/4	4	1 1/16	1,020	MAZ
36	40 1/4	28 3/8	24 1/4	9 1/2	8 1/2	8	3 1/2	3 1/2	33 1/2	7/8 x 7/8 x 5 7/8	9 3/4	4	1 1/16	1,850	MBE

Note
* E.N.P. discs require larger upper stem connection diameters on 6 inch and 10 inch valve sizes for UHMWPE seat, metal seat and fire-safe seat trims.

ANSI Class 300 Figure 370 Dimensions (inches)

Size	A	B	C	D	E	F	G	H	Q	Top Plate Drilling			Tapped Lug Data			Wt. Lbs.	Actuator Code	
										DD or Keyway	Bolt Circle	No. Holes Dia.	No. Holes	Bolt Circle	Tap			
2	4 1/8	6	4 1/16	4	2 3/8	1 1/4	9/16	9/16	1 7/8	3/8	3 1/4	4	7/16	—	—	—	8	BAB
2 1/2	4 1/8	6	4 1/16	4	1 7/8	1 1/4	9/16	9/16	2 3/8	3/8	3 1/4	4	7/16	—	—	—	9	BAB
3	5	6 5/8	4 5/8	4	1 7/8	1 1/4	5/8	5/8	2 15/16	7/16	3 1/4	4	7/16	—	—	—	12	BAC
4	6 3/16	7 1/2	5 1/2	4	2 1/8	1 1/4	3/4	3/4	3 7/8	1/2	3 1/4	4	7/16	—	—	—	20	BAD
5	7 1/4	7 9/16	5 9/16	4	2 5/16	1 1/4	3/4	3/4	4 13/16	1/2	3 1/4	4	7/16	—	—	—	25	BAD
6	8 19/32	8 3/4	6 11/16	6	2 5/16	1 1/4	7/8	7/8	5 13/16	5/8	5	4	9/16	—	—	—	32	CAE
8	10 5/8	10 1/8	8 1/16	6	2 7/8	2	1 1/8	1 1/8	7 5/8	1/4 x 1/4 x 1 5/8	5	4	9/16	—	—	—	65	CAF
10	12 3/4	11 3/8	9 3/8	6	3 1/4	3	1 3/8	1 3/8	9 9/16	5/16 x 5/16 x 2 5/8	5	4	9/16	—	—	—	95	CAG
12	14 3/4	13	10 9/16	8	3 5/8	3	1 3/8	1 1/2	11 3/8	5/16 x 5/16 x 2 5/8	6 1/2	4	1 3/16	—	—	—	145	DAG
14	16 1/4	14 1/8	12 1/4	8	4 5/8	4 1/4	1 7/8	1 7/8	12 1/2	1/2 x 3/8 x 4	6 1/2	4	1 3/16	4	20 1/4	1 1/8-8UN	270	DAJ
16	18 1/2	16	13 3/8	8	5 1/4	4 1/4	2 1/4	2 1/4	14 5/16	1/2 x 3/8 x 4	6 1/2	4	1 3/16	4	22 1/2	1 1/4-8UN	305	DAK
18	21	17	14 3/4	8	5 7/8	4 1/4	2 1/2	2 1/2	16 1/8	5/8 x 5/8 x 4	6 1/2	4	1 3/16	4	24 3/4	1 1/4-8UN	385	DBA
20	23	20 3/16	16 5/16	7 1/4	6 1/4	6 1/2	2 3/4	2 3/4	17 15/16	5/8 x 5/8 x 5 3/4	8	4	1 3/16	4	27	1 1/4-8UN	450	LA X
24	27 1/4	23 3/8	19 3/8	9 1/2	7 1/8	6 13/16	3 1/2	3 1/2	21 9/16	7/8 x 7/8 x 5 3/4	9 3/4	4	1 1/16	4	32	1 1/2-8UN	770	MAY
30	33 3/4	26 5/8	24	10	9 1/2	7 3/8	4 1/2	4 1/2	27 1/2	1 x 1 x 6 1/4	10	4	1 1/8	4	39 1/4	1 3/4-8UN	1,100	NAW
36	40 1/4	30 7/8	27 7/8	12 1/4	10 3/4	8	5	5	33 1/2	1 1/4 x 1 1/4 x 6 3/4	12	4	1 1/8	4	46	2-8UN	1,590	EBD

Lug Style

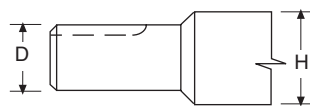

Upper Shaft/Keyway
8" thru 24"

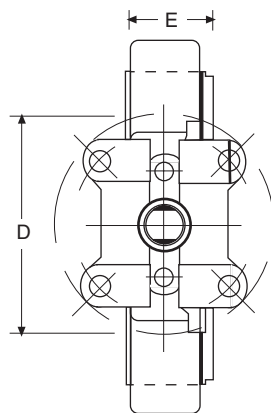

Top Plate View

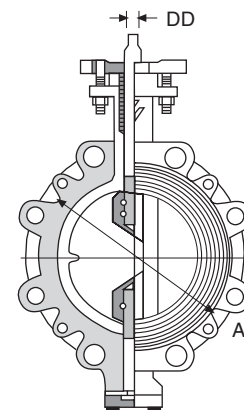
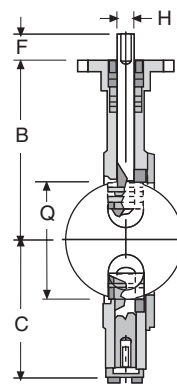

ANSI Class 150 Figure 362 Dimensions (inches)

Size	A	B	C	D	E	F	G	H	Q	Top Plate Drilling			Tapped Lug Data			Wt. Lbs.	Actuator Code	
										DD or Keyway	Bolt Circle	No. Holes	Hole Dia.	No. Holes	Bolt Circle			Tap
2	4 1/8	6	4 1/16	4	2 3/8	1 1/4	9/16	9/16	1 7/8	3/8	3 1/4	4	7/16	4	5 1/2	5/8-11UNC	13	BAB
2 1/2	4 1/8	6	4 1/16	4	1 7/8	1 1/4	9/16	9/16	2 3/8	3/8	3 1/4	4	7/16	4	5 1/2	5/8-11UNC	14	BAB
3	5	6 5/8	4 5/8	4	1 7/8	1 1/4	5/8	5/8	2 15/16	7/16	3 1/4	4	7/16	4	6	5/8-11UNC	15	BAC
4	6 3/16	7 1/2	5 1/2	4	2 1/8	1 1/4	3/4	3/4	3 7/8	1/2	3 1/4	4	7/16	8	7 1/2	5/8-11UNC	26	BAD
5	7 1/4	7 9/16	5 9/16	4	2 1/4	1 1/4	3/4	3/4	4 13/16	1/2	3 1/4	4	7/16	8	8 1/2	3/4-10UNC	31	BAD
6	8 19/32	8 3/4	6 1 1/16	6	2 1/4	1 1/4	3/4	7/8	5 13/16	1/2	5	4	9/16	8	9 1/2	3/4-10UNC	40	CAD
6*	8 19/32	8 3/4	6 1 1/16	6	2 1/4	1 1/4	7/8	7/8	5 13/16	5/8	5	4	9/16	8	9 1/2	3/4-10UNC	41	CAE
8	10 5/8	10 1/8	8 1/16	6	2 1/2	2	1 1/8	1 1/8	7 5/8	1/4 x 1/4 x 1 5/8	5	4	9/16	8	11 3/4	3/4-10UNC	63	CAF
10	12 3/4	11 3/8	9 3/8	6	2 13/16	2	1 1/8	1 3/8	9 9/16	1/4 x 1/4 x 1 5/8	5	4	9/16	12	14 1/4	7/8-9UNC	106	CAF
10*	12 3/4	11 3/8	9 3/8	6	2 13/16	3	1 3/8	1 3/8	9 9/16	5/16 x 5/16 x 2 5/8	5	4	9/16	12	14 1/4	7/8-9UNC	107	CAG
12	14 3/4	13	10 9/16	8	3 3/16	3	1 3/8	1 1/2	11 3/8	5/16 x 5/16 x 2 5/8	6 1/2	4	13/16	12	17	7/8-9UNC	160	DAG
14	16 1/4	13 1/4	11 9/16	8	3 5/8	3	1 5/8	1 5/8	12 1/2	3/8 x 3/8 x 2 5/8	6 1/2	4	13/16	12	18 3/4	1-8UN	265	DAH
16	18 1/2	14 1/2	12 9/16	8	4	3	1 5/8	1 3/4	14 5/16	3/8 x 3/8 x 2 5/8	6 1/2	4	13/16	16	21 3/4	1-8UN	305	DAH
18	21	16	13 1/16	8	4 1/2	4 1/4	1 7/8	1 7/8	16 1/8	1/2 x 3/8 x 3 7/8	6 1/2	4	13/16	16	22 3/4	1 1/8-8UN	415	DAJ
20	23	17 7/16	15 1/16	8	5	4 1/4	2 1/4	2 1/4	17 15/16	1/2 x 3/8 x 3 7/8	6 1/2	4	13/16	20	25	1 1/8-8UN	500	DAK
24	27 1/2	19 11/16	17 7/16	8	6 1/16	4 1/4	2 1/4	2 1/2	21 9/16	1/2 x 3/8 x 3 7/8	6 1/2	4	13/16	20	29 1/2	1 1/4-8UN	750	DAK
30	33 3/4	24 1/2	20 3/4	9 1/2	7 3/8	7	3	3	27 1/2	3/4 x 3/4 x 5 7/8	9 3/4	4	1 1/16	28	36	1 1/4-8UN	1,360	MAZ
36	40 1/4	28 3/8	24 1/4	9 1/2	8 1/2	8	3 1/2	3 1/2	33 1/2	7/8 x 7/8 x 5 7/8	9 3/4	4	1 1/16	32	42 3/4	1 1/2-8UN	2,250	MBE

Note

* E.N.P. discs require larger upper stem connection diameters on 6 inch and 10 inch valve sizes for UHMWPE seat, metal seat and fire-safe seat trims.

ANSI Class 300 Figure 372 Dimensions (inches)

Size	A	B	C	D	E	F	G	H	Q	Top Plate Drilling			Tapped Lug Data			Wt. Lbs.	Actuator Code	
										DD or Keyway	Bolt Circle	No. Holes	Hole Dia.	No. Holes	Bolt Circle			Tap
2	4 1/8	6	4 1/16	4	2 3/8	1 1/4	9/16	9/16	1 7/8	3/8	3 1/4	4	7/16	8	5 7/8	3/4-10UNC	17	BAB
2 1/2	4 1/8	6	4 1/16	4	1 7/8	1 1/4	9/16	9/16	2 3/8	3/8	3 1/4	4	7/16	8	5 7/8	3/4-10UNC	18	BAB
3	5	6 5/8	4 5/8	4	1 7/8	1 1/4	5/8	5/8	2 15/16	7/16*	3 1/4	4	7/16	8	6 5/8	3/4-10UNC	20	BAC
4	6 3/16	7 1/2	5 1/2	4	2 1/8	1 1/4	3/4	3/4	3 7/8	1/2	3 1/4	4	7/16	8	7 7/8	3/4-10UNC	26	BAD
5	7 1/4	7 9/16	5 9/16	4	2 5/16	1 1/4	3/4	3/4	4 13/16	1/2	3 1/4	4	7/16	8	9 1/4	3/4-10UNC	31	BAD
6	8 19/32	8 3/4	6 1 1/16	6	2 5/16	1 1/4	7/8	7/8	5 13/16	5/8	5	4	9/16	12	10 5/8	3/4-10UNC	55	CAE
8	10 5/8	10 1/8	8 1/16	6	2 7/8	2	1 1/8	1 1/8	7 5/8	1/4 x 1/4 x 1 5/8	5	4	9/16	12	13	7/8-9UNC	80	CAF
10	12 3/4	11 3/8	9 3/8	6	3 1/4	3	1 3/8	1 3/8	9 9/16	5/16 x 5/16 x 2 5/8	5	4	9/16	16	15 1/4	1-8UN	137	CAG
12	14 3/4	13	10 9/16	8	3 5/8	3	1 3/8	1 1/2	11 3/8	5/16 x 5/16 x 2 5/8	6 1/2	4	13/16	16	17 3/4	1 1/8-8UN	185	DAG
14	16 1/4	14 3/8	12 1/4	8	4 5/8	4 1/4	1 7/8	1 7/8	12 1/2	1/2 x 3/8 x 4	6 1/2	4	13/16	20	20 1/4	1 1/8-8UN	340	DAJ
16	18 1/2	16	13 3/8	8	5 1/4	4 1/4	2 1/4	2 1/4	14 5/16	1/2 x 3/8 x 4	6 1/2	4	13/16	20	22 1/2	1 1/4-8UN	432	DAK
18	21	17	14 3/4	8	5 7/8	4 1/4	2 1/2	2 1/2	16 1/8	5/8 x 5/8 x 4	6 1/2	4	13/16	24	24 3/4	1 1/4-8UN	550	DBA
20	23	20 3/16	16 5/16	7 1/2	6 1/4	6 1/2	2 3/4	2 3/4	17 15/16	5/8 x 5/8 x 5 3/4	8	4	13/16	24	27	1 1/4-8UN	850	LA X
24	27 1/4	23 3/8	19 3/8	9 1/2	7 1/8	6 13/16	3 1/2	3 1/2	21 9/16	7/8 x 5/8 x 5 3/4	9 3/4	4	1 1/16	24	32	1 1/2-8UN	1,278	MAY
30	33 3/4	26 5/8	24	10	9 1/2	7 3/8	4 1/2	4 1/2	27 1/2	1 x 1 x 6 1/4	10	4	1 1/8	28	39 1/4	1 3/4-8UN	2,450	NAW
36	40 1/4	30 7/8	27 7/8	12 1/4	10 3/4	8	5	5	33 1/2	1 1/4 x 1 1/4 x 6 3/4	12	4	1 1/8	32	46	2-8UN	2,850	EBD

Pressure/Temperature Ratings for Seat Materials

Elastomer Seats

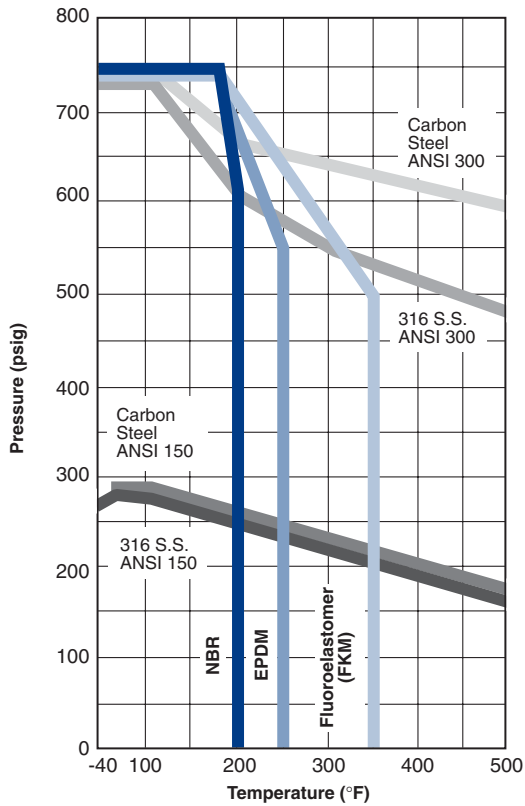

Polymer Seats

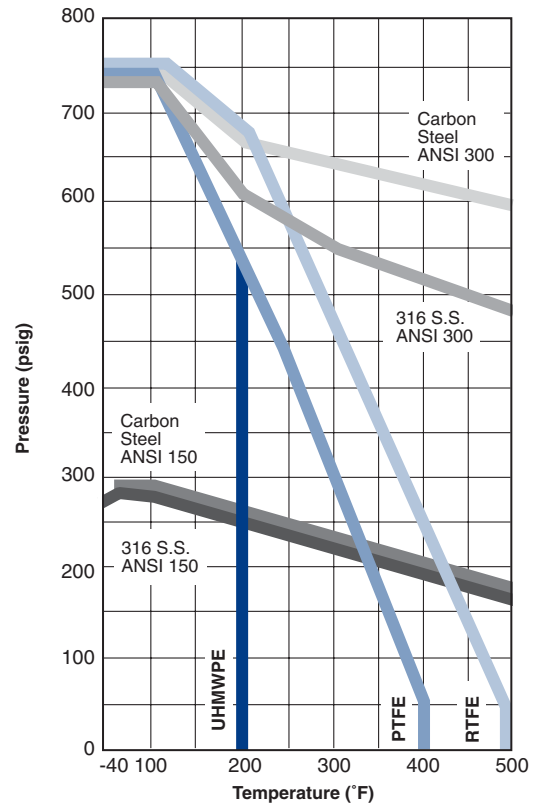

Fire-safe and Metal Seats

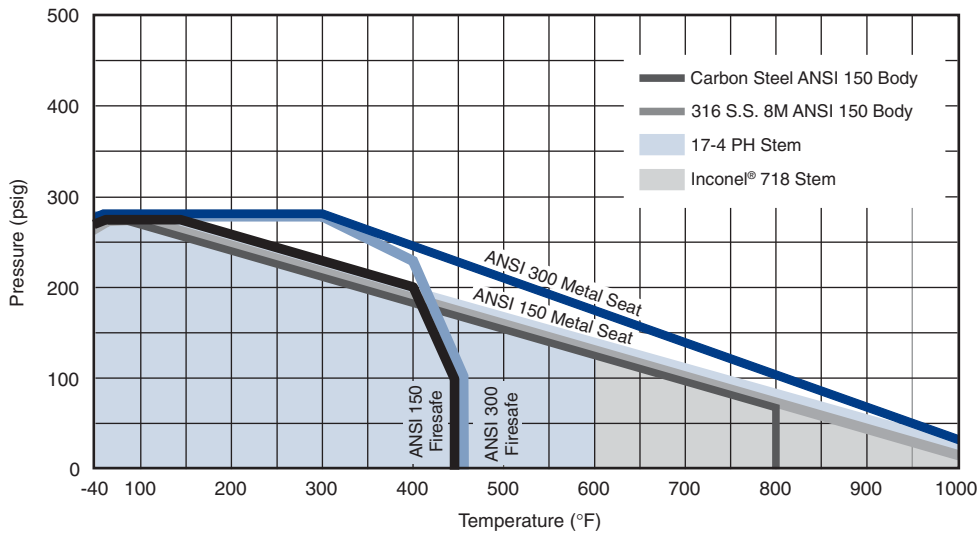

Facility Phone: 713-466-1176

tyco / Valves & Controls

www.tycovalves.com



The data presented in this bulletin is for general information only. Manufacturer is not responsible for acceptability of these products in relation to system requirements. Patents and Patents Pending in U.S. and foreign countries. All rights reserved. Printed in U.S.A. Tyco reserves the right to change product design and specifications without notice. © Copyright 2001.